

# **CAMELOT AND IDM-500**

CUSTOM CAMERAS FOR MASS PRODUCTION APPLICATIONS

**CAMELOTVIEW SAMPLE APPLICATION**

**USER GUIDE**

### **©Copyright Imaging Diagnostics 2009-2011**

This manual is copyrighted. All rights are reserved and no part of this publication may be reproduced or transmitted in any form or by any means without prior written consent.

### **Disclaimer**

The information in this manual was accurate and reliable at the time of its release. However, we reserve the right to change the specifications of the product described in this manual without notice at any time.

### **Registered Trademarks**

All other proprietary names mentioned in this manual are the trademarks of their respective owners.

### **Revision 1.5**

**Software Version 2.1.1445**

**August 2011**

<b>PREFACE .....</b>	<b>II</b>
<b>About this Document.....</b>	<b>ii</b>
<b>Conventions Used.....</b>	<b>ii</b>
<b>How to Contact Us.....</b>	<b>ii</b>
<b>CHAPTER 1. INTRODUCTION.....</b>	<b>1</b>
<b>System Architecture .....</b>	<b>1</b>
<b>Types of Cameras and their Resolutions .....</b>	<b>2</b>
<b>Advanced Features .....</b>	<b>2</b>
<b>Potential Applications (Customized to your Needs).....</b>	<b>3</b>
<b>Terms Used.....</b>	<b>3</b>
Exposure Time .....	3
Binning.....	3
<b>CHAPTER 2. INSTALLING THE CAMELOT EVK .....</b>	<b>4</b>
<b>System Requirements .....</b>	<b>4</b>
<b>Installing the Software and Camera on your PC.....</b>	<b>4</b>
Installing DirectShow (Optional) .....	10
<b>CHAPTER 3. USING THE CAMELOT EVK BASIC CONTROLS .....</b>	<b>11</b>
<b>Loading the Application.....</b>	<b>11</b>
<b>Camera Resolutions and Lens Controls.....</b>	<b>11</b>
Camera Resolution Types.....	11
Lens Controls.....	12
<b>Using the Main Screen Controls .....</b>	<b>12</b>
Start-up or Basic Controls .....	13
Getting Camera Information.....	13
Data Rate Pane .....	13
Capture Control Pane .....	14
Preview Control Pane .....	14
Capturing a Frame to a File .....	15
Exposure Control Pane .....	15
Gain Control.....	16
<b>CHAPTER 4. USING THE ADVANCED CONFIGURATION TABS .....</b>	<b>17</b>
<b>Custom Tab.....</b>	<b>17</b>
Capture ROI Pane.....	17
Raw Data Pane .....	18
Miscellaneous Pane .....	19
<b>Processing Tab.....</b>	<b>21</b>
Updating the Firmware .....	21
Sample Callback Pane .....	22
Lookup Table Pane (LUT) .....	22
Imaging Controls Pane .....	23
<b>I/O Control Tab .....</b>	<b>24</b>
General Purpose I/O Pane.....	25
PWM (Pulse-width Modulation) Control Pane.....	25
<b>Sensor Tab.....</b>	<b>26</b>
Registers Pane .....	26
Snapshot Pane.....	27
Miscellaneous Function Pane.....	28
<b>CHAPTER 5. APPENDIX.....</b>	<b>29</b>
<b>Molex Connector Pin Outs .....</b>	<b>29</b>

## About this Document

This document describes how to use the Camelot and IDM Series Evaluation Kits (EVK).

## Conventions Used

Convention	Example
Names of screens and tabs are shown in <b>Bold</b> font.	Click the <b>Video Controls</b> tab.
Keys on the Operator keyboard are enclosed in square brackets and displayed in <b>Bold</b> font.	Press the <b>[ENTER]</b> .
Action step sequences are shown as	◆ <b>To add a column:</b>

## How to Contact Us

### Website

<http://www.imagine2d.com/>

### Support

[support@imagine2d.com](mailto:support@imagine2d.com)

### Sales

[sales@imagine2d.com](mailto:sales@imagine2d.com)

## INTRODUCTION

The **Camelot** and **IDM** series are families of digital cameras for machine vision applications. Using a fast USB2 connection and an embedded digital signal processor, the cameras are capable of performing advanced image processing algorithms within the camera and buffering images internally; this decreases the bandwidth requirement between host and camera significantly. The cameras are intended for medical and industrial applications that require superior image quality and high performance.

Both the **Camelot** and **IDM** series base their design on the Blackfin processor for a complete low-power, low-cost system solution for intelligent industrial cameras. The Blackfin DSP's performance brings true intelligence to both product lines. The combined attributes of the Blackfin processor have enabled the development of a smarter and smaller embedded camera that consumes less power.

*Imaging Diagnostics'* technology has added enhanced connectivity options, USB 2.0, Ethernet, Bluetooth and Serial communication. This combination provides support for a wide range of machine vision applications.

Integrators are now more able to meet customers' demands for higher levels of industrial image-processing intelligence at reduced cost, power consumption and physical size.

### System Architecture

Raw data from the sensor is transferred to the Blackfin DSP using the integrated Parallel Peripheral Interface, PPI. Using Direct Memory Access, DMA, the image data is now transferred to the BF548 external memory for storage (64Mbytes of external memory) and further processing.



In parallel, using high speed DMA, raw data from the external memory, such as filters, lookup tables, customized fields of view, bit per pixel reduction, is transferred to the internal memory of the Blackfin for image processing, and then, using a third DMA transfer, processed data is sent via the built-in high speed USB2 Interface with practical effective rates of up to 40Mbytes per second (up to 30 FPS in 1.3Mp, 8 FPS at 5Mp, or much higher rates at VGA).

The EVK's CamelotView Sample application offers a user friendly control interface that enables users to set a specified Region of Interest (ROI), RGB gains, exposure time, frame rate and shutter width. You can capture stills (single images) in BMP, JPG or RAW formats. Added features include Look up Table, LUT, conversions, image mirroring and image binning, in the vertical and horizontal directions.

## Types of Cameras and their Resolutions

The Y Row Start and X Column Start are the actual start of pixel information in the exposed frame. When setting a ROI (Region of Interest), the StartX and StartY values must be equal to or higher than the values in this chart otherwise black lines/columns are shown.

See also [Capture ROI Pane](#) on page 17.

Resolution	Width	Height	Total Raw Pixels	Pixels for RGB32	Y Row Start	X Column Start
<b>WVGA – Global Shutter</b>					<b>4</b>	<b>1</b>
Full	752	480	360,960	1,443,840		
Half	376	240	90,240	360,960		
Quarter	188	120	22,560	90,240		
<b>1.3 Mp – Rolling Shutter</b>					<b>12</b>	<b>20</b>
Full	1280	1024	1,310,720	5,242,880		
Half	640	512	327,680	1,310,720		
Quarter	320	256	81,920	327,680		
<b>3 Mp – Rolling Shutter</b>					<b>20</b>	<b>32</b>
Full	2048	1536	3,145,728	12,582,912		
Half	1024	768	786,432	3,145,728		
Quarter	512	384	196,608	786,432		
<b>5 Mp – Rolling Shutter</b>					<b>54</b>	<b>16</b>
Full	2592	1944	5,038,848	20,155,392		
Half	1296	972	1,259,712	5,038,848		
Quarter	648	486	314,928	1,259,712		
<b>10 Mp – Rolling Shutter</b>					<b>8</b>	<b>112</b>
Full	3664	2748	10,068,672	40,274,688		
Half	1832	1374	2,517,168	10,068,672		
Quarter	916	687	629,292	2,517,168		

## Advanced Features

### NOTE

Not all of the features are available in all models of the Camelot/IDM series.

- Image processing
- Lookup table, color control (AGC, AWB)
- USB2.0 plug and play
- Ethernet connection
- Custom designed to meet your specific needs

## Potential Applications (Customized to your Needs)

- Medical
- Industrial
- Robotics
- Biometrics
- Gauging/measurement
- Identification
- Optical Character Recognition (OCR)
- Presence verification
- Motion detection
- Print inspection
- Surface inspection

## Terms Used

### Exposure Time

The Exposure time is the amount of time required until a new frame is available. Exposure time is a function of the camera PIXCLK (pixel clock), shutter width, shutter delay, frame width and binning. For more information refer to the datasheets of each specific sensor.

Except for the WVGA sensor (described below) all the Camelot and IDM series cameras use a rolling shutter. Rolling shutters cannot freeze moving objects as well as global shutters do.

### WVGA (Wide VGA Sensor - 752 x 480 pixels)

The global shutter feature of the WVGA image sensor is able to freeze moving objects as all pixels are exposed in parallel. When using a global shutter all pixels start exposing (integrating charge) simultaneously and stop exposing simultaneously. A new exposure only begins after the readout of all of the pixels is completed.

Please refer to *ID\_TN0019 Camelot, IDM-500 Exposure Time and Frame Rate.pdf* for a more detailed explanation and examples.

### Binning

When rows and columns are skipped, in half and quarter resolutions, each retained pixel takes into account an average of the skipped ones. The binned image, taken at a lower resolution, will be smoother than the unbinned image at the same resolution. The frame rate per second when using binning will be similar to the frame rate expected for Full resolution frames, since all pixels in the original full frame are exposed and then averaged.

## INSTALLING THE CAMELOT EVK

### System Requirements

These are the system requirements for using the EVK on the target PC.

Component	Minimum Requirement	Optimal Requirements
<b>Processor</b>	Core™2 Duo 2Ghz	Core™2 Quad
<b>Memory (RAM)</b>	1GB	2-4GB
<b>Free Disk Space</b>	1GB	10GB
<b>Display Screen</b>	CRT 17"	TFT 19"-22" 9:16 layout
<b>Operating system</b>	Windows XP & Windows 7, 32bit & 64bit platforms	Windows XP & Windows 7, 32bit & 64bit platforms

### Installing the Software and Camera on your PC

The Camelot and IDM series' software applications, camera drivers and camera installation are found on *Imaging Diagnostic's* site, [www.imagine2d.com](http://www.imagine2d.com), in the Support tab under [Downloads](#).

The following may be downloaded:

- [Camelot Series Datasheet](#)
- [IDM Series Datasheet](#)
- [CamelotView User's Guide](#)
- [Application Programmer's Interface, API](#) – describes all functions for communicating and controlling the Camelot and IDM series cameras.
- [Installation Guide](#) – this chapter in a separate document.
- [Current Software Version](#) – contains installation software, drivers and code.
- [CamelotView Sample Source Code](#) – source code for CamelotView sample which contains examples for using 90% of the functions in the dll library.

The installation software installs the following components:

- **CamelotView.exe** and **CamelotDll.dll** – executables and dynamic link library
- Camelot camera drivers - **idcam.sys** and **idcam64.sys**
- Application information in the registry – needed for the DirectShow version of the application
- ActiveX software component for running the DirectShow version of this application – **CamelotFilter.ax**.

- ◆ **To install the Camelot software application and Camera:**
  1. **DO NOT connect the camera to the PC at this time.**
  2. After downloading **Current Software Version**, and extracting the zip file, run **CamelotSetup.exe** from the **Camelot setup** folder.

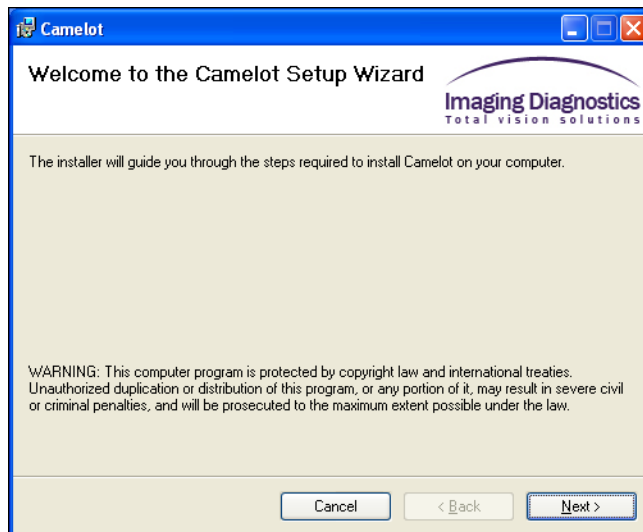

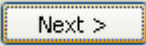
3. Click the  button.

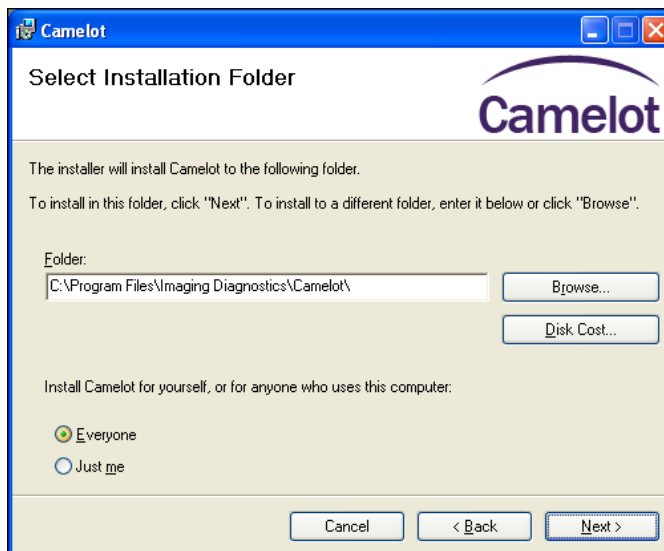

4. The default installation folder is:  
**c:\Program Files\Imaging Diagnostics\Camelot\**  
Change the installation folder if required.

Select **Just me** to restrict access to the current user alone.

5. Click the  button.

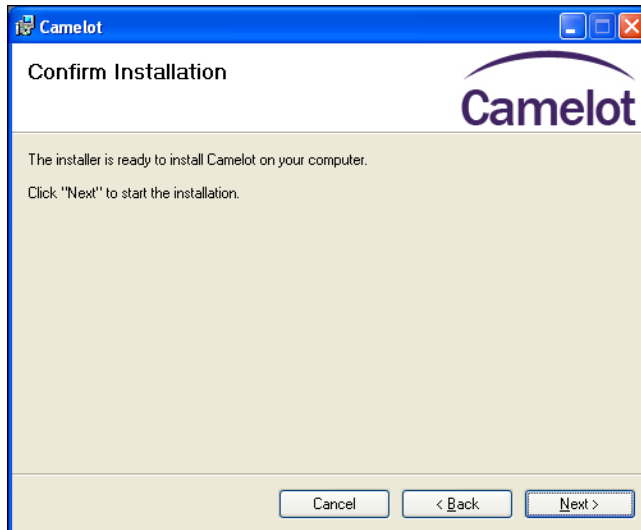

6. Click the  button to confirm the installation.

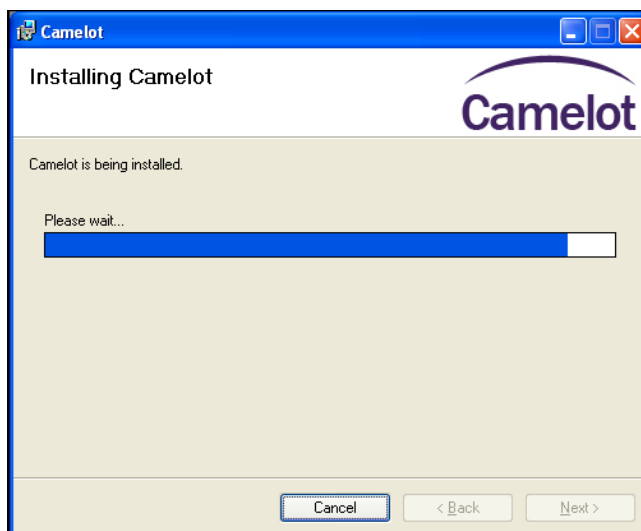

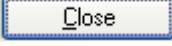

7. Click the  button.
8. Now connect the camera to a USB 2.0 port on the computer to install the driver.

9. Connect the camera to a USB 2.0 port on the computer.  
The following screen shots are from a Windows XP computer.  
For Windows 7, installation is done via the Device Manager – see below, step 18.

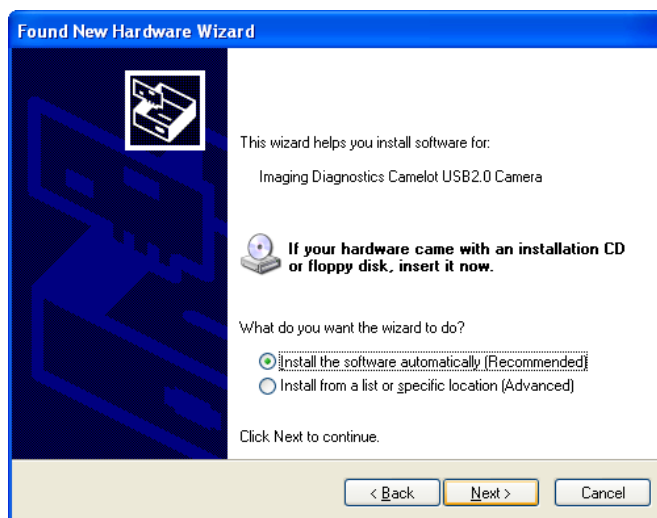

10. Select No, not this time. and click the  button.

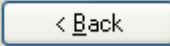
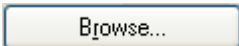

11. Select **Install the software automatically** (Recommended).
12. If the driver is not found and the installation stops, continue to the next step otherwise, skip to step 17.
13. Click the  button to return to the previous screen.
14. This time select Install from a list or specific location (Advanced).
15. Use the  button to navigate to the driver folder:  
**X:\Program Files\Imaging Diagnostics\Camelot\Drivers**  
where: **X** is the system drive. If the folder was changed in step 4, please browse to folder chosen for installation.
16. Click the  button.



17. Click the  button.

18. For **Windows 7** – after installing the drivers plug in the camera. The following may appear:



19. Open the Device manager (right-click on Computer, choose Properties, and then choose Device Manager from list). Find the Other Devices, and right-click on **ID Camelot USB2.0 Camera**

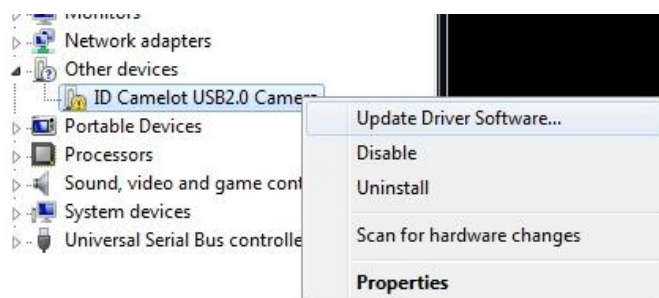

20. Choose Update Driver Software from the menu. Then choose the Browse my computer option.

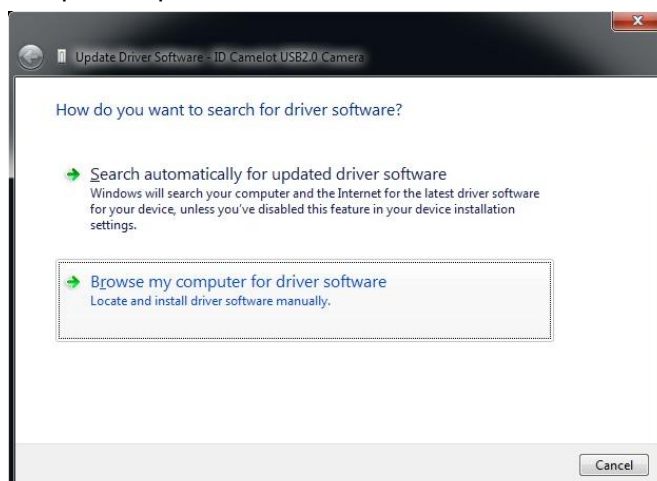

21. Browse to **X:\Program Files\Imaging Diagnostics\Camelot\Drivers** where: **X** is the system drive. If the folder was changed in step 4, please browse to folder chosen for installation. Click on Next.



22. Choose the "Install this driver software anyway" option.

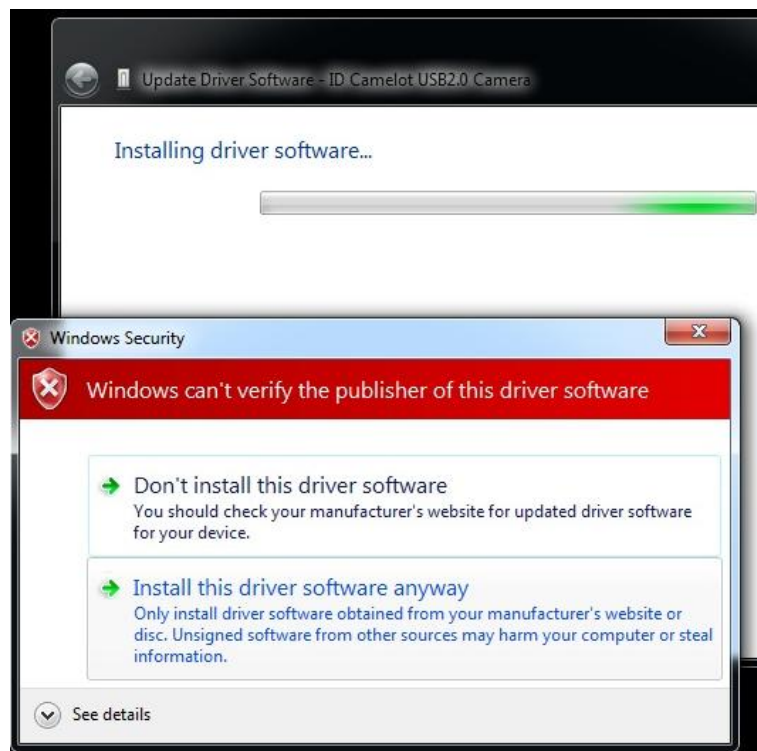

After installing the Camelot/IDM camera, check that it can now be seen in the **Device Manager**:

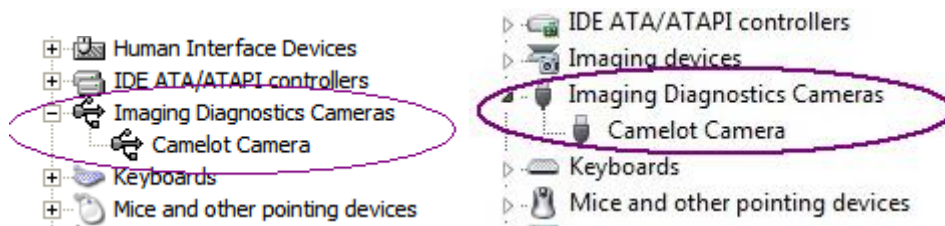

## Installing DirectShow (Optional)

### ◆ To Install DirectShow (optional):

- In order to use the **DirectShow** version of the CamelotView software, the DirectX redistributable (version 9.0 and higher) must be installed. When running Windows 7 by default the DirectX version is higher, version 11, and no action is required. To check the DirectX version on your PC go to Start → Run → and type DXDIAG. The minimum requirement for Windows XP is DirectX version 9.0c (4.09.0000.0904). The minimum requirement for Windows 7 is DirectX version 11.0.

## USING THE CAMELOT EVK BASIC CONTROLS

---

### Loading the Application

◆ **To load the Camelot EVK software application:**

- From the desktop, double-click the  Camelot application icon.  
OR  
From the **Program** list, click **Camelot Smart Camera**.

### Camera Resolutions and Lens Controls

#### Camera Resolution Types

In this application we relate to two resolution types:

1. Resolution of the camera output
  - a. **FULL** - the camera outputs frames at maximum width and height.
  - b. **HALF** - the camera outputs frames at HALF the width and HALF the height of the FULL sized frame. Thus HALF frames are actually  $\frac{1}{4}$  the size (bytes) of FULL frames.
  - c. **QUARTER** - the camera outputs frames at  $\frac{1}{16}$  the size of a FULL frame, since every three rows and every 3 columns are skipped.
2. Resolution of the **Preview** screen on the PC.
  - a. **FULL** - is the full image received from the camera is displayed as is.
  - b. **HALF** - the image received from the camera is thinned down by skipping every other row and every other column such that only  $\frac{1}{4}$  of the pixels are displayed.
  - c. **QUARTER** - only  $\frac{1}{16}$  of the pixels received from the camera are displayed.

## Lens Controls

There are three controls on the lens supplied with the EVK.

- **W-T (wide/telescope)** - zoom from wide to telescopic
- **O-C (iris open/close)** - controls how much light is allowed through the lens to brighten or darken the picture
- **N-F (near/far focus)** - finer focusing once the range has been set

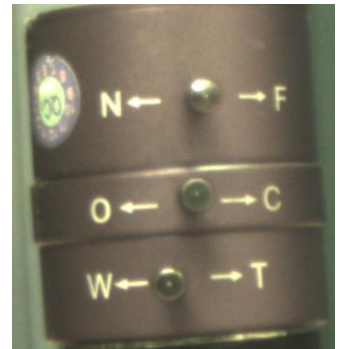

### Note

Sometimes the lens provided in the EVK will not have the lettering as in the picture. In this case the Near/Far adjustment ring is furthest from the body of the camera and the Wide/Telescopic adjustment ring is closest to the camera. The Iris Open/Close Adjustment ring will always be in the middle.

## Using the Main Screen Controls

The main screen is displayed when the application loads and contains the basic controls. The advanced functions are accessed by means of tabs in the Advanced Options pane.

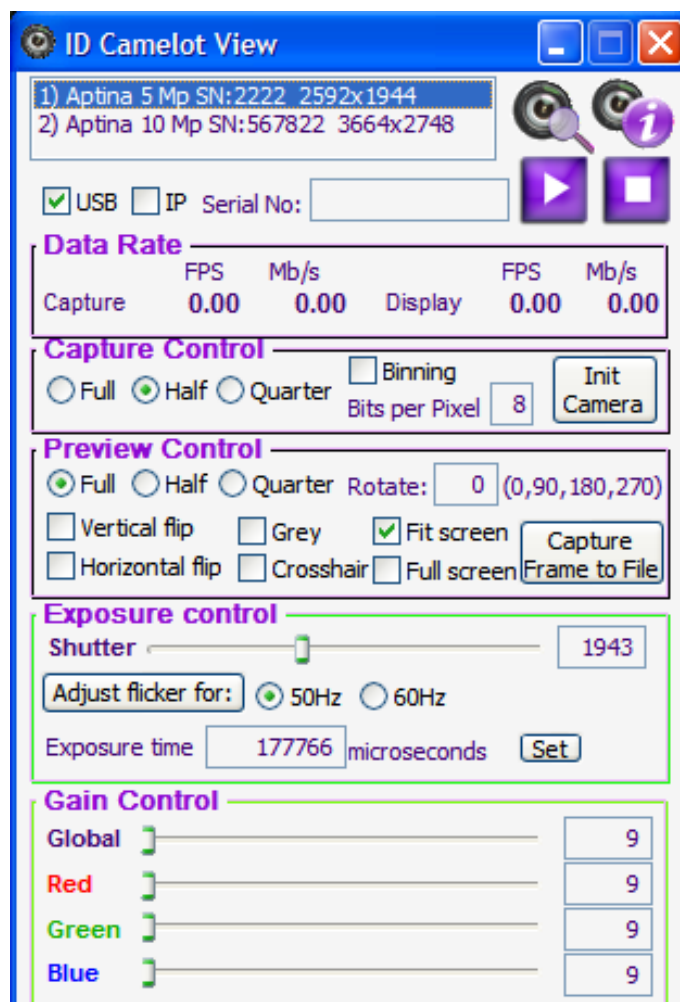





**Figure 1: Main Controls**

## Start-up or Basic Controls

These are the basic functions required to control the Camelot application.

**Table 1: Start-up Controls**

Parameter	Description
	Find connected cameras. The USB Ports of your computer are searched for any attached Camelot cameras. The LAN is searched for any Camelot cameras. It could take some time to find all of the connected cameras. This function is done when the application is opened.
	Displays camera information. Camera unique product and serial number, HW version and date, FW version and date, and IP address (if applicable). See <a href="#">Getting Camera</a> Information below.
	Runs the application and the video image display window opens.
	Pauses live video.
	Stops the camera's live video.

## Getting Camera Information

Use this function when a description of the attached cameras is required.

### ◆ To get camera information:

1. Highlight the desired camera from the list.

2. Click the  button.

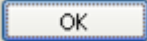

3. Click the  button to close the window.

## Data Rate Pane

Dynamically displays the data rate (FPS or Frames Per Second and Mbits/s values) of the video stream.

**Table 2: Data Rate Pane**

Parameter	Description
<b>Capture</b>	How many FPS captured by the PC (USB or IP interface)
<b>Display</b>	How many FPS were actually displayed on the PC Preview screen

## Capture Control Pane

This pane controls the capture parameters. For a more detailed explanation of resolutions, see [Camera Resolutions and Lens Controls](#) on page 11.

**Table 3: Capture Controls Pane**

Parameter	Description
<b>Full</b>	The camera transmits a full sized image. Note: There are some video cards that cannot display a Full 5Mp or Full 10Mp frame. For these setups, please uncheck the Fit to Screen checkbox to allow scrolling.
<b>Half</b>	The camera transmits a 1/4 sized image. (1/2 width x 1/2 height).
<b>Quarter</b>	The camera transmits a 1/16 sized image. (1/4 width x 1/4 height)
<b>Binning</b>	Binning is when skipped rows and columns are averaged into pixel value (in HALF and QUARTER resolutions). See <a href="#">Binning</a> on page 3.
<b>Bits per Pixel</b>	Video streaming can be done with 8 or more Bits Per Pixel, BPP. For display the video is converted to 8 bits using a default gamma conversion. If captured as RAW, it will be captured in the original format output from the camera. All Camelot cameras can output 10 BPP, while the 5Mp and 10Mp can output 12 BPP as well.
<b>Init Camera</b>	Streaming is stopped and camera is reset to original default values.

### NOTE

There are video cards that don't support displaying Full 5Mp or 10Mp frames. For these setups, please uncheck the Fit to Screen (see Table 4) checkbox to allow scrolling.

## Preview Control Pane

This pane controls how the video is viewed on the PC.  
See the section [Camera Resolutions and Lens Controls](#) on page 11.

**Table 4: Preview Controls Pane**

Parameter	Description
<b>Full</b>	The full sized image the camera generates is displayed.
<b>Half</b>	The application shrinks the full sized image received from the camera and displays it as a 1/4 sized image. (1/2 W x 1/2 H).
<b>Quarter</b>	The application shrinks the full sized image received from the camera and displays it as a 1/16 sized image. (1/4 W x 1/4 H).
<b>Rotate</b>	0, 90, 180, 270 – will rotate the display by the degrees specified. Any other value will remove rotation.
<b>Vertical Flip</b>	Flips the image vertically.
<b>Horizontal Flip</b>	Flips the image horizontally.
<b>Grey</b>	Changes the image to grey scale.
<b>Crosshair</b>	Inserts a crosshair grid in the center of the displayed image.

Parameter	Description
<b>Fit to screen</b>	When checked, video is fit (if needed, shrunk) to available screen. When not checked, scroll bars are used if screen is too big to fit frame. If scroll bars option is chosen, current FOV (Frame of View) is noted in window's title bar.
<b>Full Screen</b>	Opens Full Screen mode in which the video is maximized to fit as much of the screen as possible (keeping in proportion the width and height). The mode is exited by pressing the <input type="button" value="Off"/> button

## Capturing a Frame to a File

A frame can be captured from the video (RAW) or display stream (BMP, JPG).

### ◆ To a capture a frame to file:

1. Click the  button. The Save Frame(s) dialog appears.

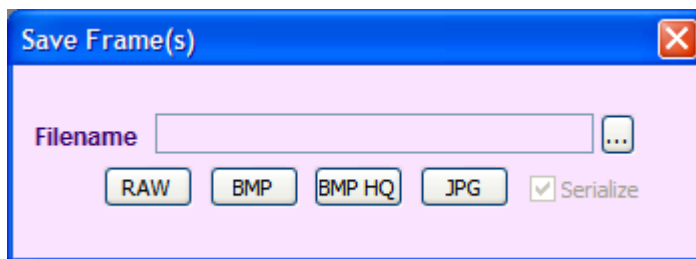

2. Enter a file name. If the suffix is not supplied, raw, bmp or jpg will be added to the name appropriately. Clicking the Browse button  opens the previously selected folder if one was previously selected.
3. Select either , ,  (High quality), or  button to save a frame in that format.

## Exposure Control Pane

In the domain of digital photography exposure is function of timing, controlled by frame size and shutter width.

**Table 5: Exposure Control Pane**

Parameter	Description
<b>Shutter width</b>	Controls how much time each frame is exposed. Similar to the mechanical Iris in the lens. This also affects Exposure Time (see below). Available Values are from 1-65,000. The slider only has a range from 1-5,000.
<b>Adjust flicker for 50/60Hz</b>	A ShutterWidth value will be chosen so that the flicker of the indoor lighting, 50Hz or 60Hz, is greatly reduced.
<b>Exposure Time</b>	A function of the camera PIXCLK (pixel clock), shutter width, shutter delay, frame size and binning. The value cannot be set lower than the minimal exposure time possible for the sensor. ShutterWidth is affected when a value is set. Value is in milliseconds.

## Gain Control

The camera's gain controls affect how much of each color is emphasized in the captured frame. The gain can be controlled individually (Red, Green and Blue) or globally by setting the **Global Gain** value. The gain values have been normalized to the range 0-1024.

**All values from 0 - 64 relate to the analog gain, where:**

1 - 32 are **real** gains of 1.0 – 4.0 in increments of 0.125

33 - 64 are **real** gains of 4.25 – 8.00 in increments of 0.25

**Values from 65 – 1024 translate as follows:**

1.3Mp cameras, 65 - 120 to an **analog** gain of 9 - 15 (since 120 is the maximum possible value all values above 120 are taken as 120).

For other cameras, 65 - 1024 to a **digital** gain of 9 – 128.

**Table 6: Gain Control Pane**

Parameter	Description
<b>Red Gain</b>	Analog and digital gains for the RED element of each frame. Values range from 0-1024.
<b>Green Gain</b>	Analog and digital gains for the GREEN element of each frame. Values range from 0-1024.
<b>Blue Gain</b>	Analog and digital gains for the BLUE element of each frame. Values range from 0-1024.
<b>Global Gain</b>	Sets the Red, Green and Blue gain values (above) to the same value.

## USING THE ADVANCED CONFIGURATION TABS

The Advanced Options section controls different video processes and sensor control.

### Custom Tab

The Custom Viewing tab enables you to

- Change the Region of Interest, ROI, of the streaming video
- Capture a RAW Full resolution frame while video streams in another resolution
- Get frame info of last frame captured
- Other output features

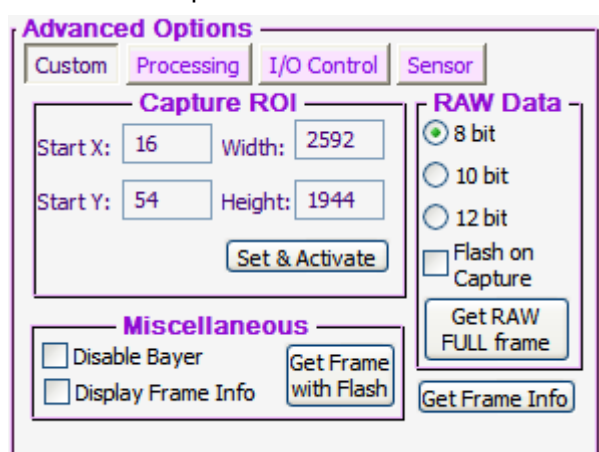

**Figure 2: Custom Tab**

### Capture ROI Pane

#### Setting the Video Capture ROI

This section describes how to set the Region of Interest, ROI, the actual area of the image captured by the camera's sensor. The required ROI relates to a Full resolution frame, and is defined by the upper/left corner coordinates (Start X, Start Y) and Width and Height. If, for example, Half capture resolution is chosen, the width and height of the ROI will be halved.

**Table 7: ROI or FOV (Frame of View) Pane**

Parameter	Description
<b>Video Capture ROI</b>	
<b>Start X</b>	<b>X</b> co-ordinate of the top left-hand corner of the sub-frame rectangle. This value shouldn't be lower than the X Column Start value for the sensor. See <a href="#">Camera Resolution Types</a> on page 11.
<b>Width</b>	Width of the sub-frame rectangle.
<b>Start Y</b>	<b>Y</b> co-ordinate of the top left-hand corner of the sub-frame rectangle. This value shouldn't be lower than the Y Row Start value for the sensor See <a href="#">Camera Resolution Types</a> on page 11

Parameter	Description
<b>Height</b>	Height of the sub-frame rectangle.
<b>Set &amp; Activate</b>	If sub-frame coordinates are valid the preview display is updated accordingly. <b>The values cannot be zero or larger than the actual image dimensions.</b> For color sensors, width and height should be multiples of 4.

◆ **To set the video capture regions:**

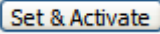
4. Set the **Capture ROI** parameters.
5. Click the  button.

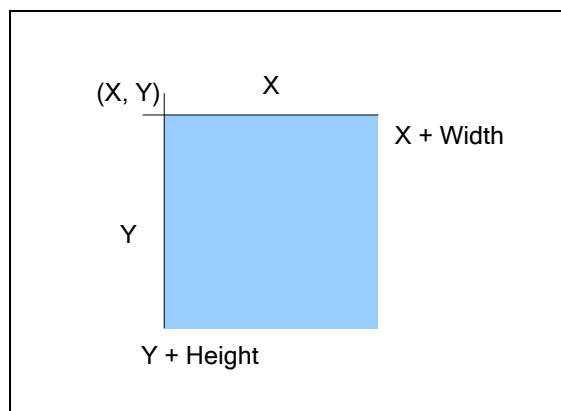

**Figure 3: ROI Image Subset (Windowing)**

## Raw Data Pane

### Getting a Full resolution, Raw Frame

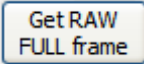
Clicking the  data button captures individual full frames from the camera, while streaming in half or quarter resolution. Raw unprocessed 10-bit and 12-bit (for 5Mp and 10Mp sensors) data can also be specified.

◆ **To set the raw data snapshot:**

1. Select a **RAW** data precision as 8, 10 or 12 bit.
2. Select **Flash on Capture** if required. The flash will be from an optional LEDs board where intensity and color are controlled by PWM (see [IO Tab](#)).

3. Click the  button.

Using the Callback function supplied with the CamelotView application, the data is saved to a file C:\Temp\captureRaw\_xx.raw, where xx is a series number. For more information about Callback functions, refer below to the [Sample Callbacks section](#) and to the *Camelot EVK API Reference* document.

**Table 8: Get Raw Data Pane**

Parameter	Description
<b>8, 10 and 12 bit</b>	RAW data is in FULL resolution. 8 bit = all cameras 10 bit = all cameras 12 bit = 5 Mp and 10 Mp
<b>Flash on Capture</b>	If the optional flash is built-in, it flashes when a Raw frame is captured. An optional LED board can also be programmed to flash.
<b>Get RAW Data</b>	Streams one frame of RAW, FULL resolution data from the camera. A Callback function is set (by default) for dealing with RawFullData. See <a href="#">Sample Callback Pane</a> on page 22 and refer to the <i>Camelot EVK API Reference</i> for more details.

## Get Frame Info

When [Get Frame Info](#) is clicked, the information of the most recently captured frame will be displayed. This information is available in the Callback function.

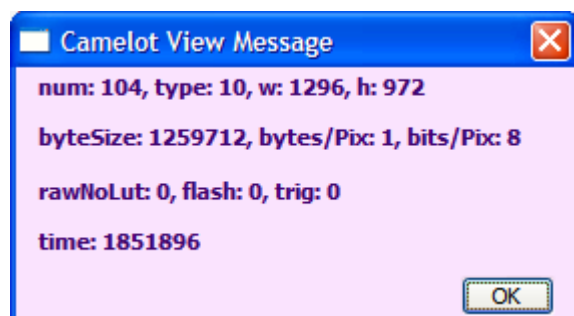

The fields displayed are:

- num – frame's number since streaming started
- type – usually 10 (Bayer 8 bit), but can be any value from this list:
  - NO\_FRAME = 0
  - BAYER\_8\_BIT = 10 // regular 8 bit per pixel output
  - BAYER\_RAW = 11 // 8, 10 or 12 bit raw full data
  - RGB\_24 = 13 // BMP using RGB24
  - RGB\_32 = 18 // BMP using RGB32
  - RGB\_8\_MONO = 19 // RGB8 - monochrome
- w,h – width and height
- byteSize – size of frame in bytes
- bytes/Pix – bytes per pixel
- bits/Pix – bits per pixel
- rawNoLut – RAW frame without LUT applied
- flash – frame was captured with/without flash
- trig – frame was captured due to an external trigger
- time – in milliseconds from when the camera was powered up

## Miscellaneous Pane

If you select the **Disable Bayer** checkbox, the Bayer conversion is not performed and the picture is converted from an 8-bit grayscale to a 32-bit grayscale. This saves display time and has no affect on the actual picture quality.

Monochrome sensors will have this button checked by default.

**Table 9: Miscellaneous Pane**

Parameter or Button	Description
Disable Bayer	When selected 256 shades of grey are used to display the frame. No Bayer color conversion is performed. Should be checked for monochrome sensors.
Display Frame Info	The camera embeds in the picture the frame number and time (mm:ss:mmm).
Get Frame with Flash	While streaming, a frame will be captured and displayed with flash. The PWM will control the flash intensity. The frame can be analyzed in the Callback function and will have the <code>pCbData-&gt;FrameInfo.WithFlash == TRUE</code> characteristic. See <a href="#">Sample Callback Pane</a> on page 22 and refer to the <i>Camelot EVK API Reference</i> for more details.

## Processing Tab

This tab enables you to update the camera's firmware, load a lookup table, LUT, enable the **Callback** functions and perform simple Image processing and color correction.

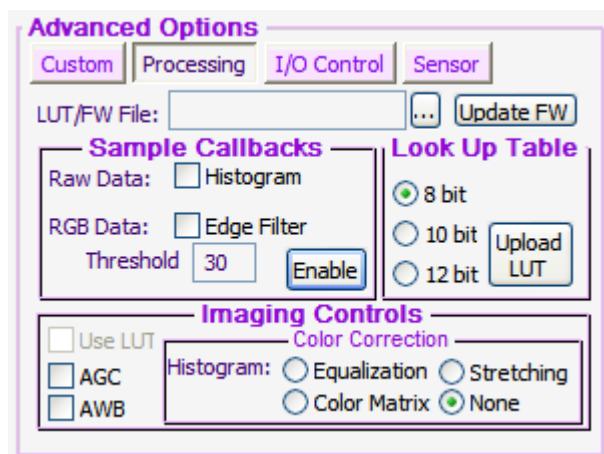

**Figure 4: Processing Tab**

## Updating the Firmware

The **Camelot\_FW.Idr** file is an Analog Devices™ loader file used to update the camera firmware. The firmware can be updated using either your own **\*.ldr** file or one downloaded from our website.

### WARNING

This function uploads data to the camera – an operation that could render it non-functional if an invalid custom LDR file is being used.

For this reason, please send us your custom LDR files for validation to insure that the camera boots after loading your file:

[support@imagine2d.com](mailto:support@imagine2d.com)

### IMPORTANT NOTE

We periodically provide update versions for the camera's Firmware that can be downloaded from our website <http://www.imagine2d.com/>.

### Downloads Contain

- **CamelotView.exe** – the SampleApplication executable.
- **Camelot.dll** – a dynamic link library which must be placed in the same directory in which the executable is run.
- **CamelotView.zip** – contains the latest update sources.
- **Camelot\_FW.Idr** – is the loader file with the new code for the camera. This file must be loaded using the example application (Update FW) or by calling the API function and supplying the path to the file.
- **ID\_debugger.exe** – a debugger window that can be used when programming to debug application. **See the EVK API for more details.**

#### ◆ To update the Firmware:

1. Select the FW file using the **Browse** button.
2. Click the  button.

**Table 10: Update Firmware Controls**

Parameter or Button	Description
<b>LUT/FW File</b>	Use the Browse button to select a LUT or FW file.
<b>Update Firmware Button</b>	<b>REMEMBER to ONLY upload LDR files that have been validated by ID first.</b> Enables updating the selected camera firmware. Use the Browse button to select the FW update file.

## Sample Callback Pane

### Setting the Callback Parameters

#### NOTE

Callback functions provide additional standard or proprietary processing. These are just examples and can be replaced with your own processing code. For more information, refer to the Camelot EVK API document.

#### ◆ To setup the Callback parameters:

1. Select the **Callback** function.
2. Click the  button.

Callback functions are either enabled (if selected) or disabled (if cleared). **See the EVK API for more details.**

**Table 11: Callback Functions Pane**

Parameter or Button	Description
<b>Raw Data: Histogram</b>	Computes intensities of R, G, and B pixels and displays graph on video screen.
<b>RGB Data: Edge Filter</b>	An algorithm used in image processing and computer vision to identify points in a digital image at which the image brightness changes sharply, or an edge.
<b>Threshold</b>	Value used by the Edge filter.
<b>Enable Button</b>	Enables the selected callback function.

## Lookup Table Pane (LUT)

### Uploading the Lookup Table (LUT)

#### ◆ To upload the LUT (lookup table):

1. Select the LUT file to upload using the **Browse** button.
2. Set the **Lookup Table** parameters:  
Choose 8, 10 or 12 bit (the LUT output to the PC is 8 bits).
3. Click the  button.

#### NOTE

With 5Mp cameras, the Camera FPS rate (see Sensor Tab page 28) should be changed to the maximum USB/IP frame rate possible (e.g. 8 for FULL resolution USB) that can be transferred, otherwise image defects could occur.

4. The Use LUT checkbox is now enabled (in Imaging Controls pane). When checked, the video shown will be a LUT translation of the camera's captured image.

**Table 12: Look Up Table Pane**

Parameter or Button	Description
<b>8, 10 and 12 bits</b>	LUT output to the PC is 8 bits only. 10 bit = 1.3, 3,5 Mp and WVGA(1024 values) 12 bit = 5 Mp (4096 values)
<b>Upload LUT</b>	Uploads a LUT file to the camera. This provides required image color transformation. The file is checked for syntax before it is uploaded.

### What is a LUT (Look-up Table)

A Look-up Table converts the image pixel resolution from the camera's actual output (8, 10 or 12 bits) to an 8-bit format where the highest permissible value is 255. This is done by assigning the same 8-bit values to ranges of higher bit values as shown in the examples below. A LUT for 8-bit conversion must have 256 lines, for 10-bit conversion this file must have 1024 lines, and a 12-bit conversion file must have 4096 lines.

**Table 13: 10 and 12 bit LUT Pane**

10 bit Image Values	8 bit Conversion	12 bit Image Values	8 bit Conversion
0 - 5	0	0 - 2	0
6 - 8	1	3	1
9 - 11	2	4	2
12 - 13	3	5	3
14	4	6	4
15 - 16	5	7	5
17	6	8	6
19	7	9	7
20	8	10 -13	8
...	...	14 - 16	9
		17	10
		...	...
1021 - 1023	255	4090 - 4095	255

### Imaging Controls Pane

**Table 14: Imaging Controls Pane**

Checkbox or Button	Description
<b>Use LUT</b>	Whether uploaded LUT (lookup table) should be applied.
<b>AGC</b>	Should AGC (Automatic Gain Control) be used when processing the captured frames? This is done in the camera. When selected, the Exposure Control Pane and Gain Control Pane are disabled, but the dynamically updated values are displayed.
<b>AWB</b>	Should AWB (Automatic White Balance) be applied to the captured frames. This is done in the camera. When selected, the Exposure Control Pane and Gain Control Pane are disabled, but the dynamically updated values are displayed.

Checkbox or Button	Description
<b>Color Correction</b>	All of these options are done in the PC after Bayer transform.
<b>Histogram Equalization</b>	Used as a method in image processing of contrast adjustment using the image's histogram.
<b>Histogram Stretching</b>	Often called Normalization, it is a simple image enhancement technique (linear scaling function) that attempts to improve the contrast of an image by stretching the range of intensity values it contains to span a desired range of values. For example, the the full range of pixel values that the image type concerned allows. There are more sophisticated methods available but the results are much harsher.
<b>Color Matrix</b>	ColorMatrix operations are performed in the RGBA colorspace (red, green, blue, alpha). A ColorMatrix consists of a 5x5 matrix, with color values normalized to 1 for full intensity (255 -> 1.0).
<b>None</b>	Turns off all color correction.

## I/O Control Tab

General purpose registers and PWM control.

### NOTE

To utilize the PWM, GPIO and LED state functions, the use of the connector described in [Appendix One](#), is required.

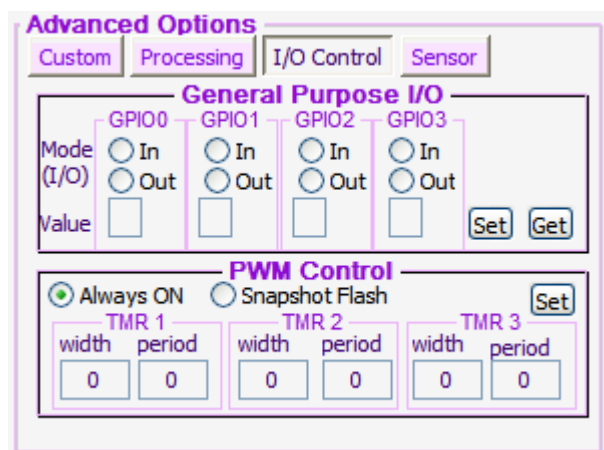

**Table 15: General Purpose I/O Pane**

Parameter	Description
<b>In</b>	IN direction – value can only be read.
<b>Out</b>	OUT direction - Value can be set and/or read.
<b>Value</b>	0 or 1 – low/high.
<b>Set Button</b>	Sets the entered directions and values in the actual GPIO register.
<b>Get Button</b>	Reads the values of the selected GPIO registers according to the selected directions.

## General Purpose I/O Pane

### NOTE

To fully utilize the PWM, GPIO and LED state functions, a separate optional board is required.

#### ◆ To use the General Purpose I/O pane:

1. Click the  button to see the current state of the GPIO pins.
2. Select the GPIO pin and choose the direction of the pin - **IN** or **OUT**.
3. Enter a value (0 or 1) if the pin's direction is **OUT**.
4. Click the  button to set the data.

## PWM (Pulse-width Modulation) Control Pane

Here Pulse-width modulation (PWM) is used to modulate the duty cycle, to control the amount of power sent to a load. In this case it is used primarily for the brightness of the illumination LEDs (lamps), or any other optionally connected device.

### NOTE

To fully utilize the PWM, GPIO and LED state functions, a separate optional board is required.

#### ◆ To use the PWM Control pane:

1. Select Always ON or Snapshot Flash.
2. Select a timer.
3. Enter **Width** and **Period** values.
4. Click the  button

**Table 16: PWM Control Pane**

Parameter	Description
<b>Always ON</b>	(Optional) LEDs or any illumination device (or any other PWM devices) that is constantly ON.
<b>Snapshot Flash</b>	(Optional) LEDs or any illumination device (or other PWM devices) that are turned on when a Snapshot or RAW FULL frame is requested.
<b>TMR Width</b>	(Optional) A value that together with the TMR period controls the PWM Duty Cycle and that of the connected load. A LED is lit during the PWM duty cycle.
<b>TMR Period</b>	(Optional) The amount of units in the Total PWM period.
<b>Set Button</b>	Sets the entered values in the camera.

## Sensor Tab

The **Sensor** tab enables you to both query and modify the sensor's registers, use Snapshot mode, and set different camera parameters.

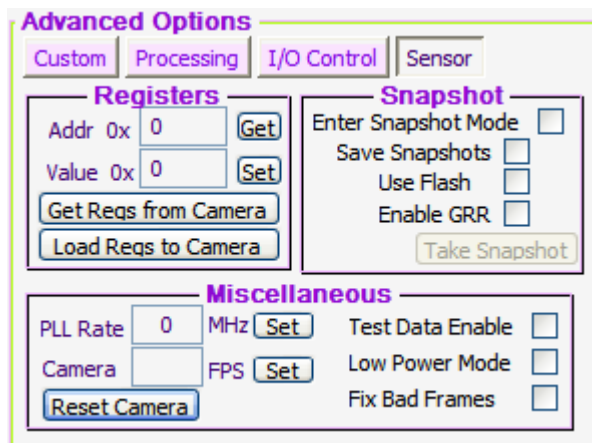

### Registers Pane

You can get or set the values of the registers.

#### WARNING

Changing the register values could cause the software application to stop working. Please consult the sensor's Data Sheet before accessing registers.

- ◆ **To read a register:**
  1. In the **Register** pane, enter a hexadecimal register address (**addr**)
  2. Click the **Get** button to see the register's current value.
- ◆ **To write to a register:**
  1. In the **Register** pane, enter a hexadecimal register address and a value.
  2. Click the **Set** button.

**Table 17: Registers Pane**

Parameter	Description
<b>Addr and Value</b>	<b>Use caution when changing the registers as this could cause the application to hang.</b>  Use the <b>Get</b> button to read the registers and the <b>Set</b> button to change their values.
<b>Get</b>	Fetches the selected register data in hexadecimal format.
<b>Set</b>	Sets the selected register data in hexadecimal format.
<b>Get Regs from Camera</b>	Dumps defined registers to a text file named <b>c:\regVals_SENSOR_TYPE_SERIAL_NUM.txt</b>
<b>Load Regs to Camera</b>	Uploads register values (up to 100) to the camera from a file named <b>c:\reginputList.txt</b> . See below for file format.

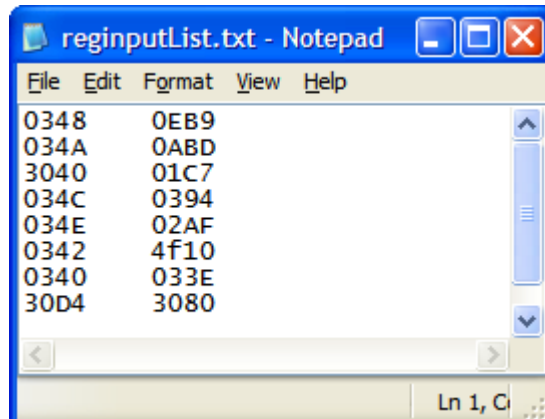

Register number is given (in 4 character HEX), <TAB>, and then register value (in 4 character HEX).

## Snapshot Pane

### ◆ To use the Snapshot pane:

- Select **Enter Snapshot Mode** if required and use the   button to take a snapshot.

The   button mimics an external trigger you can optionally add to camera.

**Table 18: Snapshot Pane**

Parameter	Description
<b>Enter Snapshot Mode</b>	Enters Snapshot mode. Camera stops outputting live video and waits for a Snapshot trigger.
<b>Save Snapshots</b>	Opens dialog in and user supplies type (Raw, Bmp, BmpHQ, Jpg), path and file name where snapshots should be saved. Snapshots can be serialized and saved with consecutive numbers. See Figure 5 <a href="#">below</a> .
<b>Use Flash</b>	Should flash be used when snapshot is triggered? The flash is external LEDs controlled by PWM – <b>see <a href="#">I/O Tab</a> for more information</b>
<b>Enable GRR</b>	For 5Mp models, enables Global Reset Release mode which starts exposing all pixels simultaneously.
<b>Take Snapshot</b>	Triggers a snapshot. An external GPIO trigger on the unit can be used, also. <b>See <a href="#">IO_Tab</a> for more details</b>

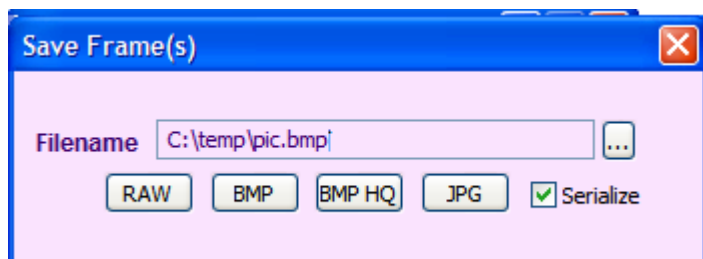

**Figure 5: Save Snapshot Pane**

## Miscellaneous Function Pane

### ◆ To use the Miscellaneous pane:

1. Enter a **PLL** rate value and then click the **Set** button.

This function is only available for the 5Mp sensor. The camera starts up with a PLL rate of 60MHz.

#### Note

**Changing the PLL rate will change the functioning of the video, FPS and may cause video defects.**

2. Check **Test Data Enable** if constant, unchanging output data is required. Each sensor has its own type of Test data.
3. **Camera FPS** controls how many frames per second are captured by the camera. The rationale behind lowering the FPS is to free the DSP's CPU for processing. When using LUT on the 5Mp USB camera, the FPS rate should be set to 8 (for full resolution).

**Table 19: Miscellaneous Pane**

Parameter	Description
<b>PLL Rate</b>	An advanced option to change the Chip's clock rate. Only applicable to the 5Mp camera. Default is 60MHz.
<b>Set Button</b>	Set the PLL Rate specified.
<b>Test Data Enable</b>	Enable constant Test data
<b>Camera FPS</b>	Set camera's capture rate. Used to give camera's DSP more CPU time for processing.

## CHAPTER 5

## APPENDIX

## Molex Connector Pin Outs

**Connector description:** The GPIO connector on the Camelot Main board uses a 20 pin Molex Pico-clasp 1mm Pitch board to wire connector ,Molex PN : 5011902017 , mating connector : 501189-2010 .

And crimp pins. PN: 501193-2000

The mapping of the pins is different for the Camelot USB and Ethernet models.

## USB

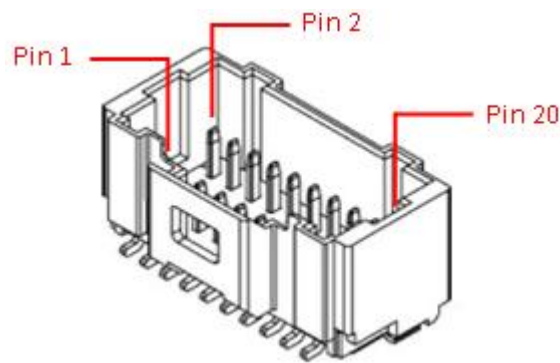

Pin	Pin name	Pin description	Remarks	Pin	Pin name	Pin description	Remarks
1	PB0	GPIO- Open-drain	10K Pull-Up	2	Power		5V
3	PC7	GPIO		4	Power		5V
5	PC8	GPIO		6	PB9	TMR1 (PWM)	
7	PG6	SPI1_SEL2#		8	PB10	TMR2 (PWM)	
9	PG8	SPI1_SCK		10	PG11	SPI1_SS#	
11	PG9	SPI1_MISO		12	PC9	GPIO	
13	PG10	SPI1_MOSI		14	PC10	GPIO	
15	PB4	UART2-TX	10K Pull-Up	16	PC11	GPIO	
17	GND			18	PH3	TMR9 (PWM)	10K Pull-Up
19	GND			20	PB5	UART2-RX	10K Pull-Up

## Ethernet

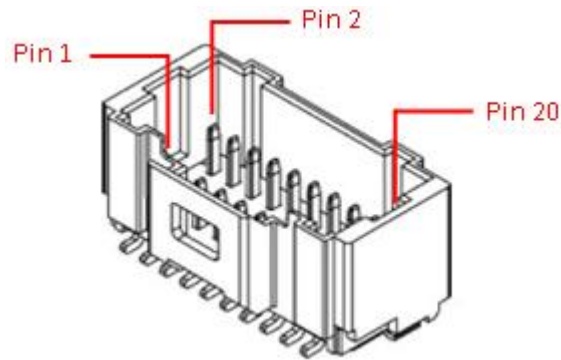

Pin	Pin name	Pin description	Remarks	Pin	Pin name	Pin description	Remarks
1	PB0	GPIO- Open-drain	10K Pull-Up	2	Power	5V	
3	PC7	GPIO	serial 33Ω	4	Power	5V	
5	NC			6	PB9	TMR1 (PWM)	serial 33Ω
7	NC			8	PB10	TMR2 (PWM)	serial 33Ω
9	PG8	SPI1_SCK		10	PC8	GPIO/SD_D0	
11	PG9	SPI1_MISO		12	PC9	GPIO/SD_D1	
13	PG10	SPI1_MOSI		14	PC10	GPIO/SD_D2	
15	PG11	SPI1_SS#		16	PC11	GPIO/SD_D3	
17	GND			18	Power	3.3V	
19	GND			20	Power	3.3V	

## IDM-500 GPIO Connector

The GPIO connector on the Main board uses a 5-pin plug - Molex PN: 5019390500

Pin	Signal
1	GPIO1 - PH6 - STROBE
2	GPIO2 - PH5
3	GPIO3 - PH4
4	GPIO4 - TRIGGER
5	GND

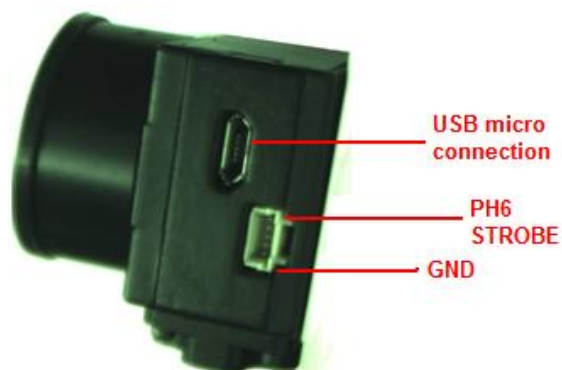

Imaging Diagnostics invites comments and feedback on this and all of our documentation. Please contact us at one of the email addresses below.

**Website**

<http://www.imagine2d.com/>

**Support**

We would appreciate any feedback you have about the Camelot EVK.

[support@imagine2d.com](mailto:support@imagine2d.com)

**Sales**

Please contact us if we can assist you in building your own custom applications.

[sales@imagine2d.com](mailto:sales@imagine2d.com)



a member of the

